

UPSHUR COUNTY EMERGENCY SERVICES DISTRICT NO. 1

DECEMBER 9, 2024

6:00 P.M.

MINUTES

The regular meeting of the Upshur County Emergency Services District No. 1 Board of Commissioners was held on December 9, 2024, in the Upshur County Courtroom, Upshur County Courthouse, 150 E. Jefferson Street, Gilmer, Texas.

The District considered and acted upon the following matters:

- 1) **Call to order and establish quorum.** The meeting was called to order at 6:00 p.m. by Kenny Southwell and a quorum was present with Kenny Southwell, Scott Mischnick, Brian Jones, Raymond Cook, and Anthony Depaepe being present.
- 2) **Public Comment.** Bracy Sweat made an announcement that the deadline for submitting applications for the Texas Health and Wellness Grants is December 31st. Matt Burnett with the Texas Forest Service announced Workers Compensation, Accidental Death and Dismemberment, Accident and Sickness, Cancer, and other grants through TFS that are available and are covered at \$190.00 per person. Raymond Cook announced the upcoming Spring schools open for registration. Kenny Southwell announced that the Upshur County ESD #1 website has an active calendar that is updated with events and training classes.
- 3) **Announcements:**
 - A. **Update on ESD coverage map;**

Marc Nichols, Emergency Management Coordinator, was present and announced that the maps are working and are online and have been uploaded to the Upshur County Sheriff's Department CAD system.
 - B. **Update on Harmony station;**

Kenny Southwell announced that the sheetrock, painting, cabinets, septic, water, and fiber optics are installed and that the station should be complete by the January meeting.
 - C. **Update on Ewell Substation (Lafayette) remodel;**

Penny Neighbours announced that they are planning on ripping out the inside office walls and bathroom and run new plumbing. There will be new bathrooms and lighting. Trees have been cleared out.
 - D. **Update on Ewell's new truck;**

Kenny Southwell announced that the new truck is here and that they will be sending it to Sulphur Springs to get it rigged and the bed and skid unit installed.

E. Reminder to Chiefs to submit list of active members;

Kenny Southwell reminded the Chiefs to submit the list of their active members by the January meeting. Brian Jones reiterated the importance of providing this list to the Board for the retirement system he has been working on.

F. Reminder to Chiefs to submit list of drivers at the January meeting;

Kenny Southwell reminded the Chiefs to submit a list of their approved drivers at the January meeting.

G. Notify Chiefs of January 6th meeting with Alpine Software which will be a time for them to ask questions regarding the reporting software; and

Kenny Southwell announced that there will be a presentation of the Alpine Software on January 6, 2025 at 6:00 p.m. for any that want to attend and to ask questions that they might have.

H. Grants awarded to departments.

Kenny Southwell announced that three of our departments have received grants. He further announced that the committee (consisting of himself, Marc Nichols, Josh Bardwell, Nicole Stanley, and Scott Mischnick) has met and drawn up specs for the new units and sent out to companies that are interested. All three departments have requested a custom cab. The goal is to purchase 4 new units and 1 remount.

4) Consent agenda items:

A. Approval of the minutes of the November 11, 2024 meeting;

B. Accounts Payable; and

C. Approval of reimbursements to departments for invoices submitted for the month of October 2024.

Brian Jones made a motion with a second by Raymond Cook to approve items 4 A-C. Motion carried 5-0. Unanimous vote in favor. (SEE ATTACHED)

5) Discuss and take action to pay TCMC this month's draw of \$99,707.46 minus the 10% retainage of \$9,970.75 which equals the amount of \$89,736.71 for the new construction of the Harmony VFD station.

Motion by Anthony Depaepe with a second by Brian Jones to pay TCMC this month's draw of \$99,707.46 minus the 10% retainage of \$9,970.75 which equals the amount of \$89,736.71 for the new construction of the Harmony VFD station. Motion carried 5-0. Unanimous vote in favor.

6) Discuss and take action on recommendations of Accountant for closing FYE24 books and make any budget amendments at the request of the Accountant.

Kenny Southwell announced that he had spoken with Karen Jacks and that she did not require any budget amendment from the Board to close out the books for FYE24. No need for any action.

7) Discuss and take action for purchase of new chassis for Harmony VFD and remount.

First In presented a proposal for the 2026 chassis in the amount of \$143,633.00 plus the HGAC fee of \$2,000.00. Kenny Southwell announced that the chassis needed to be ordered this month. First In presented a proposal for the repair to the EONE pumper at a cost of \$198,855.00. Kenny Southwell announced that we would have to pay the \$143,633.00 at the time the chassis comes in. We will then have to pay the \$49,355.00 to start the remount work. Kenny Southwell further announced that Harmony VFD received the \$100,000.000 grant to go towards this chassis. Motion by Brian Jones with a second by Scott Mischnick to approve the purchase from First In in the amount of \$143,633.00 for the chassis and \$49,355.00 as the down payment for the repairs to the EONE pumper. Motion carried 5-0. Unanimous vote in favor. (SEE ATTACHED)

8) Discuss and take action to post for bids of sale of the ladder truck as a salvage vehicle.

Raymond Cook has received paperwork from the tax office to apply for a lost title. Kenny Southwell announced that we want to post for bids for the sale of the ladder truck as a salvage vehicle. He further announced that we need permission to post this on Facebook. Motion by Raymond Cook to post it on Facebook once we get some kind of inkling for approval or disapproval of a lost title. Scott made a second to the motion. Motion carried 5-0. Unanimous vote in favor.

9) Presentation of new reporting software.

No presentation at this time.

10) Discuss and take action to execute the 2024-2025 dispatching contract with the City of Gilmer.

Motion by Scott Mischnick with a second by Brian Jones to execute the 2024-2025 dispatching contract with the City of Gilmer. Motion carried 5-0. Unanimous vote in favor.

11) Discuss and take action on any insurance claim payouts to rural departments.

None.

12) Discuss and take action on any grant reimbursement requests submitted.

None.

13) Discuss and take action on items to be considered for next month's agenda.

#6; Lafayette remodel

14) Adjournment.

Meeting adjourned at 7:15 p.m.

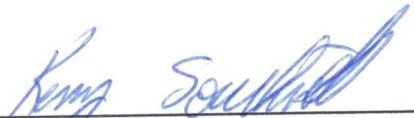

Presiding Officer Signature
Title: President

Date: 1-13-2025

ACCOUNTS PAYABLE:

1)	City of Gilmer (November dispatching services)	\$ 3,000.00
2)	Terri Ross (November services)	\$ 750.00
3)	Terri Ross (Reimbursement for postage)	\$ 14.60
4)	Anthony Depaepe (Reimbursement – pymt to Kalahari)	\$ 195.00
5)	Upshur County Appraisal District (1 st qtr payment)	\$ 11,052.70
6)	City of Gilmer (1 st qtr payment)	\$ 22,500.00
7)	City of Big Sandy (1 st qtr payment)	\$ 8,750.00
8)	City of Gladewater (1 st qtr payment)	\$ 8,750.00
9)	Bill Knight Ford (Ewell new truck)	\$ 58,887.07
10)	Scott Mischnick (Reimbursement for Google invoice)	\$ 46.05
11)	ETEX (Draft)	\$ 103.95
12)	Swepco (Draft)	\$ 29.02
13)	TCMC (draw for Harmony station, Agenda item #5)	\$ 89,736.71

DEPARTMENT BILLS TO BE PAID:

1) BETTIE VFD	\$ 8,307.72
2) EAST MOUNTAIN VFD	\$ 2,362.92
3) EWELL VFD	\$ 1,682.55
4) HARMONY VFD	\$ 559.76
5) PLEASANT GROVE VFD	\$ 5,051.09
6) PRITCHETT VFD	\$ 3,212.31
7) SIMPSONVILLE VFD	\$ 5,152.71
8) WEST MOUNTAIN VFD	\$ 2,165.89

updated



Apparatus Proposal

Date: November 21, 2024

The Proposal has been prepared for:

Upshur County ESD

PO Box 1432

Gilmer, TX 75644

First-IN Public Safety Solutions is pleased to offer The Upshur County ESD . one (1) Freightliner 2 door extended cab chassis. This vehicle shall be in accordance with the attached specifications. The purchase price shall include equipment as detailed in the First- IN Proposal.

Delivery will be **F.O.B 300** days from precon and signed approval packet. Terms of payment shall be payment due on delivery acceptance of chassis at First in Public Safety Solutions in Sulphur Springs, Texas.

Purchase price for chassis: \$ \$143,633.00

HGAC Fee: \$ 2000.00

QUOTE GOOD FOR 15 DAYS

The pricing provided is exclusive of all Federal, State and Local taxes and any other fees, which may apply unless specifically noted herein. The customer is responsible for all applicable Federal, State and Local Taxes as well as associated Fees.

**3097 Interstate Highway 30 Service Road NE
Sulphur Springs, Texas 75482
903-348-0252**

FREIGHTLINER SPECIFICATION PROPOSAL

Vehicle Configuration

M2 112 PLUS CONVENTIONAL CHASSIS
2026 MODEL YEAR SPECIFIED
SET BACK AXLE - TRUCK

General Service

DOMICILED, USA (EXCLUDING CALIFORNIA AND CARB OPT-IN STATES)
FIRE/EMERGENCY SERVICE
FREIGHTLINER LEVEL II WARRANTY
EXPECTED FRONT AXLE LOAD: 16000 lbs
EXPECTED REAR DRIVE AXLE LOAD: 31000 lbs
EXPECTED GROSS VEHICLE CAPACITY: 47000 lbs

Engine

CUM L9 450EV HP @ 2100 RPM; 2200 GOV RPM, 1250 LB-FT @ 1200 RPM, FIRE/EMERGENCY

Engine Equipment

EPA 2010/GHG 2024 CONFIGURATION
NFPA COMPLIANT EMBER SCREEN AND FIRE-RETARDANT DONALDSON AIR CLEANER
DR 12V 300 AMP 40-SI BRUSHLESS PAD MOUNT ALTERNATOR WITH REMOTE BATTERY VOLTAGE SENSE
(3) DTNA GENUINE, FLOODED STARTING, MIN 3000CCA, 555RC, THREADED STUD BATTERIES WITH POSITIVE JUMP START POST
BATTERY BOX FRAME MOUNTED
WIRE GROUND RETURN FOR BATTERY CABLES WITH ADDITIONAL FRAME GROUND RETURN
POSITIVE LOAD DISCONNECT WITH CAB MOUNTED CONTROL SWITCH MOUNTED OUTBOARD DRIVER SEAT
CUMMINS TURBOCHARGED 18.7 CFM AIR COMPRESSOR WITH INTERNAL SAFETY VALVE
C-BRAKE BY JACOBS WITH LOW/OFF/HIGH BRAKING DASH SWITCH
RH MTD HORIZONTAL AFTERTREATMENT SYSTEM ASSEMBLY WITH RH HORIZONTAL TAILPIPE
AIR POWERED ON/OFF ENGINE FAN CLUTCH
AUTOMATIC FAN CONTROL WITHOUT DASH SWITCH
CUMMINS SPIN ON FUEL FILTER

COMBINATION FULL FLOW/BYPASS OIL FILTER
1300 SQUARE INCH ALUMINUM RADIATOR WITH AUXILIARY COOLING
ANTIFREEZE TO -34F, OAT (NITRITE AND SILICATE FREE)
EXTENDED LIFE COOLANT
GATES BLUE STRIPE COOLANT HOSES OR EQUIVALENT
CONSTANT TENSION HOSE CLAMPS FOR COOLANT HOSES
ELECTRIC GRID AIR INTAKE WARMER
DELCO 12V 38MT HD STARTER WITH INTEGRATED MAGNETIC SWITCH

Transmission

ALLISON 3000 EVS 5 SPD AUTOMATIC TRANSMISSION

Transmission Equipment

MAGNETIC PLUGS, ENGINE DRAIN, TRANSMISSION DRAIN, AXLE(S) FILL AND DRAIN
HEAVY DUTY ELECTRONIC TRANSMISSION SHIFT CONTROL, COLUMN MOUNTED
TRANSMISSION PROGNOSTICS - ENABLED 2013
WATER TO OIL TRANSMISSION COOLER
TRANSMISSION OIL CHECK AND FILL WITH ELECTRONIC OIL LEVEL CHECK
SYNTHETIC TRANSMISSION FLUID (TES-295 COMPLIANT)

Fire Pump

CUSTOM DRIVELINE JACKSHAFT SPACER FOR FIRE PUMP

Front Axle and Equipment

DETROIT DA-F-16.0-5 16,000# FL1 71.0 KPI/3.74 DROP SINGLE FRONT AXLE
MERITOR 16.5X6 Q+ CAST SPIDER CAM FRONT BRAKES, DOUBLE ANCHOR, FABRICATED SHOES
FIRE AND EMERGENCY SEVERE SERVICE, NON-ASBESTOS FRONT LINING
FRONT OIL SEALS
HALDEX AUTOMATIC FRONT SLACK ADJUSTERS
TRW TAS-85 POWER STEERING

Front Suspension

16,000# TAPERLEAF FRONT SUSPENSION
GRAPHITE BRONZE BUSHINGS WITH SEALS
FRONT SHOCK ABSORBERS

Rear Axle and Equipment

31,000 LB FIRE/EMERGENCY SERVICE SINGLE REAR AXLE
IRON REAR AXLE CARRIER WITH STANDARD AXLE HOUSING

MXL 17T MERITOR EXTENDED LUBE MAIN DRIVELINE WITH
HALF ROUND YOKES
MERITOR 16.5X7 P CAST SPIDER CAM REAR BRAKES, DOUBLE
ANCHOR, CAST SHOES
FIRE AND EMERGENCY SEVERE SERVICE NON-ASBESTOS
REAR BRAKE LINING
REAR OIL SEALS
HALDEX AUTOMATIC REAR SLACK ADJUSTERS

Rear Suspension

31,000# FLAT LEAF SPRING REAR SUSPENSION WITH HELPER
AND RADIUS ROD FOR FIRE/EMERGENCY SERVICE
SPRING SUSPENSION - 1.50" AXLE SPACER
FORE/AFT CONTROL RODS

Brake System

AIR BRAKE PACKAGE
WABCO 4S/4M ABS WITH TRACTION CONTROL WITH ESC
STANDARD AIR SYSTEM PRESSURE PROTECTION SYSTEM
BW AD-9 BRAKE LINE AIR DRYER WITH HEATER ALL TANKS
CUSTOM STEEL AIR BRAKE RESERVOIRS
BW DV-2 AUTO DRAIN VALVE WITH HEATER - WET TANK

Wheelbase & Frame

(200 INCH) WHEELBASE / (108 INCH) CA
11/32X3-1/2X10-15/16 INCH STEEL FRAME 120KSI
(47 INCH) REAR FRAME OVERHANG

Chassis Equipment

CUSTOMER INSTALLED SPECIAL BUMPER
REMOVABLE FRONT TOW/RECOVERY DEVICE
FENDER AND FRONT OF HOOD MOUNTED FRONT MUDFLAPS
GRADE 8 THREADED HEX HEADED FRAME FASTENERS

Fuel Tanks

50 GALLON RECTANGULAR ALUMINUM FUEL TANK - LH
6 GALLON DIESEL EXHAUST FLUID TANK
FUEL/WATER SEPARATOR WITH WATER IN FUEL SENSOR AND
12 VOLT PREHEATER

Tires

MICHELIN X LINE ENERGY Z 315/80R22.5 20 PLY RADIAL FRONT
TIRES
MICHELIN X WORKS XDY 315/80R22.5 20 PLY RADIAL REAR
TIRES

Hubs

CONMET PRESET PLUS PREMIUM IRON FRONT HUBS

WEBB IRON REAR HUBS

Wheels

22.5X9.00 10-HUB PILOT POLISHED ALUMINUM FRONT WHEELS

22.5X9.00 10-HUB PILOT POLISHED ALUMINUM REAR WHEELS

Cab Exterior

138 INCH BBC HIGH-ROOF EXTENDED ALUMINUM
CONVENTIONAL AIR RIDE CAB

BOLT-ON MOLDED FLEXIBLE FENDER EXTENSIONS

NFPA COMPLIANT LH AND RH EXTERIOR GRAB HANDLES

HOOD MOUNTED CHROMED PLASTIC GRILLES

FIBERGLASS HOOD & FIREWALL INSULATION

DUAL 25 INCH ROUND STUTTER TONE HOOD MOUNTED AIR
HORNS WITH LH/RH FOOT SWITCHES

DUAL ELECTRIC HORNS

LED HEADLIGHT ASSEMBLY AND INCANDESCENT
MARKER/TURN LAMP WITH CHROME BEZELS & DAYTIME
RUNNING LIGHTS

LED AERODYNAMIC MARKER LIGHTS

DUAL 102" WEST COAST BRIGHT FINISH HEATED MIRRORS
WITH LH AND RH REMOTE

LH AND RH 8 INCH BRIGHT FINISH CONVEX MIRRORS
MOUNTED UNDER PRIMARY MIRRORS

REAR WINDOW DELETE

TINTED DOOR GLASS LH AND RH WITH TINTED NON-
OPERATING WING WINDOWS

20X23 INCH LH AND RH TINTED SIDE WINDOWS

RH AND LH ELECTRIC POWERED WINDOWS & DOOR LOCKS

1-PIECE SOLAR GREEN GLASS WINDSHIELD

2 GALLON WINDSHIELD WASHER RESERVOIR WITH FLUID
LEVEL INDICATOR, FRAME MOUNTED

Cab Interior

GRAY & CARBON VINYL INTERIOR

MOLDED PLASTIC DOOR PANELS WITH ALUMINUM KICKPLATES
LOWER DOORS

BLACK MATS WITH PREMIUM INSULATION

FORWARD ROOF MOUNTED CONSOLE

AM/FM/WB WORLD TUNER RADIO WITH AUXILIARY INPUT

(2) CUP HOLDERS LH AND RH DASH

M2 DASH WITH DUAL USB CHARGING PORTS (2) IN DASH
HEATER, DEFROSTER AND AIR CONDITIONER

MAIN HVAC CONTROLS WITH RECIRCULATION SWITCH

SOLID-STATE CIRCUIT PROTECTION AND FUSES

12V NEGATIVE GROUND ELECTRICAL SYSTEM

LED PREMIUM CAB LIGHTING

H.O. BOSTROM SIERRA AIR-50 HIGH BACK AIR SUSPENSION
DRIVER SEAT WITH ADJUSTABLE RECLINE, FIXED LUMBAR
NFPA COMPLIANT

H.O. BOSTROM TANKER 450 SCBA NON-SUSPENSION
PASSENGER SEAT WITH UNDERSEAT STORAGE, SECURE ALL
READY CUSHION NFPA COMPLIANT

BLACK DURAWEAR FABRIC SEAT COVERS, SEAT BOLSTERS
AND INSERTS

NFPA 1901-2009 HIGH VISIBILITY ORANGE SEAT BELTS

ADJUSTABLE TILT AND TELESCOPING STEERING COLUMN

4-SPOKE 18 INCH BLACK STEERING WHEEL

DRIVER AND PASSENGER INTERIOR SUN VISORS

Instruments & Controls

BRIGHT ARGENT FINISH GAUGE BEZELS

LOW AIR PRESSURE INDICATOR LIGHT AND AUDIBLE ALARM

DUAL NEEDLE PRIMARY AND SECONDARY AIR PRESSURE
GAUGE

ELECTRONIC AIR RESTRICTION INDICATOR DISPLAYED IN
DRIVER DISPLAY

ELECTRONIC CRUISE CONTROL WITH CONTROLS ON
STEERING WHEEL SPOKES

PREMIUM INSTRUMENT CLUSTER WITH 5.0 INCH TFT COLOR
DISPLAY

FIRE AND EMERGENCY SERVICE VEHICLES ENGINE WARNING

2 INCH ELECTRIC FUEL GAUGE

ELECTRICAL ENGINE COOLANT TEMPERATURE GAUGE

DIGITAL TRANSMISSION OIL TEMPERATURE IN DRIVER
DISPLAY

ENGINE AND TRIP HOUR METERS INTEGRAL WITHIN DRIVER
DISPLAY

ELECTRIC ENGINE OIL PRESSURE GAUGE

ELECTRONIC MPH SPEEDOMETER WITH SECONDARY KPH
SCALE

ELECTRONIC 3000 RPM TACHOMETER

IGNITION SWITCH CONTROLLED ENGINE STOP

DIGITAL VOLTAGE DISPLAY INTEGRAL WITH DRIVER DISPLAY

SINGLE ELECTRIC WINDSHIELD WIPER MOTOR WITH DELAY

ROTARY HEADLAMP SWITCH, MARKER LIGHTS/HEADLIGHTS
SWITCH

ONE VALVE PARKING BRAKE SYSTEM WITH DASH VALVE
CONTROL

SELF CANCELING TURN SIGNAL SWITCH WITH DIMMER,
HEADLAMP FLASH, WASH/WIPE/INTERMITTENT

INTEGRAL ELECTRONIC TURN SIGNAL FLASHER

Paint Design

ONE SOLID CUSTOM BASE/CLEAR COAT COLOR CAB PAINT
BLACK, HIGH SOLIDS POLYURETHANE FRAME/CHASSIS PAINT

Weight Summary

	Weight Front	Weight Rear	Total Weight
Factory Weight*	8404 lbs	4610 lbs	13014 lbs

(+) Weights shown are estimates only. If weight is critical, contact Customer Application Engineering.

(***) All cost increases for major components (Engines, Transmissions, Axles, Front and Rear Tires) and government mandated requirements, tariffs, and raw material surcharges will be passed through and added to factory invoices.

DIMENSIONS

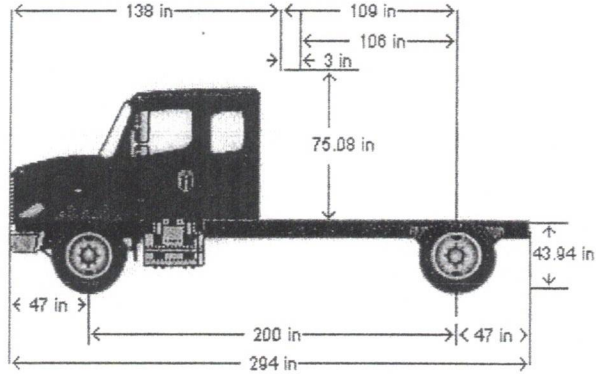



Apparatus Proposal

Date: November 21, 2024

The Proposal has been prepared for:

Upshur County ESD

PO Box 1432

Gilmer, TX 75644

First-IN Public Safety Solutions is pleased to offer The Upshur County ESD . one (1) repair to EONE fire body. This vehicle shall be in accordance with the attached specifications. The purchase price shall include equipment as detailed in the First- IN Proposal.

Delivery will be **F.O.B 300** days from precon and signed approval packet. Terms of payment shall be down payment at contract signing of \$49,355.00 and final payment at final inspection at facility in Sulphur Springs Texas.

Repair price to EONE pumper: \$ 198,855.00

QUOTE GOOD FOR 15 DAYS

The pricing provided is exclusive of all Federal, State and Local taxes and any other fees, which may apply unless specifically noted herein. The customer is responsible for all applicable Federal, State and Local Taxes as well as associated Fees.

**3097 Interstate Highway 30 Service Road NE
Sulphur Springs, Texas 75482
903-348-0252**